

Status: 05/2020



Products need labeling
Print and apply systems



HERMES Q

Made in Germany

Please note: **Hermes+** was discontinued on December 31, 2019. Manufacture has been switched step by step to **HERMES Q**. Repairs of **Hermes+** are guaranteed at least until December 2025, so are spare parts deliveries.



HERMES Q

Designed for automated printing and labeling in production lines

1.1



The slim one

to print small labels

Label printer		HERMES Q2	
Printable resolution	dpi	300	600
Print speed	up to mm/s	300	150
Print width	up to mm	56.9	54.1
Label roll outside diameter	mm	205 / 305	
Label width	up to mm	58	

1.2



The universal one

Best-selling industrial device, offering a wide range of accessories

Label printer		HERMES Q4.3		HERMES Q4	
Printable resolution	dpi	200	300	300	600
Print speed	up to mm/s	300	300	300	150
Print width	up to mm	104	108.4	105.7	105.7
Label roll outside diameter	mm	205 / 305			
Label width	up to mm	114			

1.3



The wide one

to print Odette, UCC and GS1 labels in logistics applications

Label printer		HERMES Q6.3	
Printable resolution	dpi	200	300
Print speed	up to mm/s	250	250
Print width	up to mm	168	162.6
Label roll outside diameter	mm	205 / 305	
Label width	up to mm	174	

Labels on rolls

HERMES Q2, Q4, Q6.3



Label roll diameter 205 mm

HERMES Q2, Q4, Q6.3



Label roll diameter 305 mm

Slim labels

on rolls or reels

HERMES Q2, Q4



If labels are processed on liner materials less than 20 mm wide, the ribbon needs protruding on both sides to prevent from folding. For this purpose, the label guide is offset by 7 mm with spacers.

Directions of label transfer

HERMES QL



to the left

HERMES QR



to the right

Covers

HERMES Q2, Q4, Q6.3



suitable for roll diameters up to 205 mm

Sample applications

PCB labeling



Package labeling



Container labeling



Details



1 Operation panel

Operating the device is intuitive and simple with the help of self-explanatory symbols to configure settings.

2 Ribbon holder

Three-part tightening axles enable the ribbon to be replaced quickly and easily.

3 Rugged metal chassis

made of cast aluminum; basis to assemble all units

4 Applicator assembly

They are mounted on hinge pins and can be pivoted in the case of material replacement or maintenance.

5 Plungers

One plunger is fixed on the inner side. A second one is moved that far to the label margin, until a good print image evokes.

6 Print head

All print heads are freely interchangeable at equal width. Easy replacement

7 Automatic ribbon saving (option)

The print head is lifted during label feed and the ribbon is stopped.

8 Print roller removal

It can be easily removed or inserted in the cases of cleaning or wear.

9 Peel-off plate, pivoted

to improve label transfer onto packaging.

10 Label unwinder

By means of the swing lever and a brake integrated, labels are unwound with constant tension.

11 Liner tape rewinder

After all the labels have been transferred, the liner tape is fully rewound. The three-part tightening axle allows the liner tape to be inserted and removed easily.

12 Draw system

Liner material is inserted between the draw roller and the pinch roller. Labels are peeled off by synchronous print roller transport. If labels exceed 150 mm in height or are applied by demand modules 5114/16, a steel roller is required.

13 Label sensor

A gap sensor or a reflective sensor position the imprint precisely on the label and detect the end of the material.

Imprint accuracy







The smaller a label, the higher are the requirements on the imprint accuracy. With the help of the adjustable slip correction, print offset can be reduced by ± 0.2 mm.

Operation panel

Operating the device is intuitive and simple with the help of self-explanatory symbols to configure settings.

- 1 **LED signal:** Power ON
- 2 **Status bar:** data reception, record data stream, ribbon pre-warning, SD memory card / USB memory stick plugged in, Bluetooth, WLAN, Ethernet, USB slave, time
- 3 **Printer status:** Ready, Pause, number of labels printed in a print job, label in peel-off position, awaiting external start signal
- 4 **USB slot** to connect the Service Key or a memory stick, in order to transfer data to the IFFS memory

5 Operation

-  Printing and labeling in individual steps
-  Jump to menu
-  Reprint last label
-  Interrupt and continue print job
-  Stop and delete all print jobs
-  Label feed



Setup options



Print parameters



Print position Y

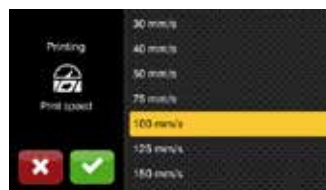

Print speeds

Depending from the orientation of assembly, display is either in landscape or portrait mode.



Printer rotated by 90°



Video tutorials

External operation panel

providing the same functionality as on the printer

Display in landscape or portrait mode

Users are free to choose whether to operate the printer on the external panel or on the one integrated in the device.

Printer connection: USB 2.0 Hi-speed device

- 1 **LED signal:** Power ON
- 2 **USB slot** to connect the Service Key or a memory stick, in order to transfer data to the IFFS memory
- 3 **Connecting cable USB**, lengths 1.8 to 16 m
If length succeeds 3 m, use only specified cables.
For dimensions see assembly instructions



Print heads



All print heads are freely interchangeable at equal width. They are automatically detected and calibrated by the CPU. The print distance to the locating edge can be adjusted.

Major data such as running performance, maximum operating temperature and heat energy are directly stored in the print head. The data can be read at the plant.

Print heads for HERMES Q2, HERMES Q4 - 300, 600 dpi
providing sharp-edged print images
suitable for small fonts and graphics on typeplates
suitable for markings on materials with high energy needs

Print heads for HERMES Q4.3, HERMES Q6.3 - 200, 300 dpi
durable; suitable for rough surroundings and thermal direct printing

Print rollers



Two types of material:

Print rollers DR

Coating: synthetic rubber

They suit for highly accurate imprint and are provided as standard.

Print rollers DRS

Coating: silicone

They have an extra long service life at a higher imprint tolerance.

Interfaces



1 to connect a **SD memory card**

2 **2 x USB Host** to connect a Service Key, USB memory stick, keyboard, USB Bluetooth adapter, USB WLAN stick, warning light, an external operation panel

3 **USB 2.0 Hi-speed device** to connect a PC

4 **Ethernet 10/100 Mbit/s**

5 **RS232C** 1,200 to 230,400 baud/8 bit

6 **Digital I/O interface;** 25 pin SUB-D socket connector compliant with IEC/EN 61131-2, type 1+3, All inputs and outputs are galvanically isolated and protect from reverse polarity. In addition, outputs are short circuit protected.

Inputs PNP

Start printing or labeling
Print first label
Reprint
Delete print job
Label removed
Stop printing or labeling
Label feed
Label rotation 90° for appl. 4214
Pause
Reset

Outputs PNP, NPN

Device ready
Print data available
Initial / upper end position
Paper feed ON
Label in peel-off position
Label transfer / lower end position
Pre-warning to ribbon ending
Pre-warning to labels ending
End of ribbon and/or end of labels
Collective error

Accessory:

7 **2-Port Ethernet Switch 10/100 Mbit/s**

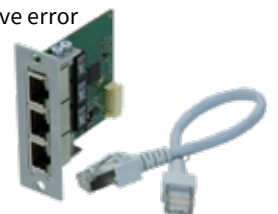

Technical data

● typical ■ standard □ option

Label printer		Type	HERMES Q2		HERMES Q4.3		HERMES Q4		HERMES Q6.3	
Printing method	Thermal transfer		●	●	●	●	●	●	●	●
	Thermal direct		-	-	●	●	-	-	●	●
Printable resolution	dpi		300	600	200	300	300	600	200	300
Print speed	up to mm/s		300	150	300	300	300	150	250	250
Print width	up to mm		56.9	54.1	104	108.4	105.7	105.7	168	162.6
Direction of label transfer			L to the left or R to the right							
Print distance to locating edge	mm		1	1	1	1	1	1	1	1
	with autom. saving L/R mm		-	-	2.2/1.6	0/-0.7	1/1	1/1	0.2/0.2	2.9/2.9
Material										
Labels			Paper, PET, PE, PP, PI, PVC, PU, acrylate, Tyvec							
	on roll		●		●		●		●	
	on reel		●		-		-		-	
Labels ¹⁾	Width	mm	4 - 58		10 - 114		10 - 114		46 - 174	
	Height	from mm	3		4		4		6	
	Thickness	up to mm	0.60		0.60		0.60		0.60	
Liner material	Width roll	mm	24 - 62		24 - 118		24 - 118		50 - 178	
	Width ²⁾ reel or roll	mm	10 - 24		-		10 - 24		-	
	Thickness	up to mm	0.16		0.16		0.16		0.16	
Roll unwinder	Outside diameter	roll up to mm	205 / 305		205 / 305		205 / 305		205 / 305	
		reel up to mm	205		-		-		-	
	Core diameter	mm	76							
	Winding		outside or inside							
Roll rewinder	Outside diameter	up to mm	155 / 205							
	Core diameter	mm	76							
Ribbon ³⁾	Ink side		outside or inside							
	Roll diameter	up to mm	90							
	Core diameter	mm	25.4							
	Variable length	up to m	600							
	Width	mm	25 - 67		25 - 114		25 - 114		50 - 170	
	Automatic saving		-		□		□		□	
Printer dimensions and weights										
Width	mm		207		260		260		320	
Height	with roll diameter 205 / 305	mm	400 / 430							
Depth	with roll diameter 205 / 305	mm	400 / 500							
Weight	with roll diameter 205 / 305 approx. kg		15 / 16		16 / 17		16 / 17		20	
Label sensor with position indication										
Gap sensor	for		labels, punch marks or print marks and end of material							
Reflective sensor	reflex from below	for	print marks on non-transparent liner materials and end of material							
Distance of sensor to locating edge	mm		2 - 26		2 - 60		2 - 60		2 - 60	
Material passage	mm		2							
Electronics										
Processor 32 bit clock rate	MHz		800							
Main memory (RAM)	MB		256							
Data memory (IFFS)	MB		50							
Slot to connect a SD memory card (SDHC, SDXC)			■							
Battery for time and date, real-time clock			■							
Data memory when power is switched off (e.g. serial numbering)			■							
Interfaces										
RS232C 1,200 to 230,400 baud/8 bit			■							
USB 2.0 Hi-speed device to connect a PC			■							
Ethernet 10/100 Mbit/s			LPD, RawIP printing, SOAP webservice, OPC UA, WebDAV DHCP, HTTP/HTTPS, FTP/FTPS, TIME, NTP, Zeroconf, SNMP, SMTP, VNC							
1 x USB host on the operation panel	for		Service Key, USB memory stick, USB WLAN stick, USB Bluetooth adapter							
2 x USB host on the back of the device	for		keyboard, barcode scanner, USB memory stick, warning light, USB WLAN stick, USB WLAN stick with a rod antenna, USB Bluetooth adapter, external operation panel							
Peripheral connection USB host, 24 VDC			■							
Digital I/O interface with 10 inputs and 11 outputs			■							
2-Port Ethernet Switch 10/100 Mbit/s			□							

¹⁾ Limitations may apply to small labels, thin materials or strong adhesives. Critical applications need to be tested.

²⁾ Spacers provided for label unwinder and liner rewinder to guide the liner centered atop the labels.

³⁾ The ribbon should at least correspond with the width of the liner material.

Technical data

■ standard □ option

Operating data			
Power supply	100-240 VAC, 50/60 Hz, PFC		
Power consumption	Standby <10 W / typical 150 W / up to 300 W		
Temperature / Operation humidity	Stock	+5 - 40°C / 10 - 85 %, not condensing	
	Transport	0 - 60°C / 20 - 85 %, not condensing	
Approvals	CE, FCC Class A, ICES-3		
	in preparation	cULus, CB, CCC	
Operation panel			
Colored LCD touch display	Screen diagonal	"	4.3
	Resolution Width x Height	px	480 x 272
Setup options			
	Print Labels Ribbon Peel-off Apply Interfaces Error	Region: - Language - Country - Keyboard - Time zone Time Display: - Brightness - Power saving mode - Orientation Interpreter	
Status bar			
	Data reception Record datastream Ribbon pre-warning SD memory card plugged in USB memory stick plugged in	Bluetooth WLAN Ethernet USB slave Time	
Monitoring			
	Ribbon Labels Print head	Direc. of winding Pre-warning End of material Pre-warning End Voltage Temperature open	Pinch roller open Periphery error
Test routines			
System diagnostics	on start-up, including print head detection		
Information display, test printout, analysis	Status printout Fonts list List of devices WLAN status Record print data on memory card	Test grid Label profile List of events Monitor mode	
Status reports	- Printout of device settings, e.g. print lengths and service hours - Device status request by software command - Display of, e.g., network errors, no links, barcode errors, periphery errors, etc.		
Fonts			
Font types provided internally	5 bitmap fonts: 12 x 12 dots 16 x 16 dots 16 x 32 dots OCR-A OCR-B	7 vector fonts: AR Heiti Medium GB-Mono CG Triumvirate Condensed Bold Garuda HanWangHeiLight Monospace 821 Swiss 721 Regular and Bold	
to be stored	TrueType fonts		
Character sets	Windows-1250 to -1257 DOS 437, 737, 775, 850, 852, 857, 862, 864, 866, 869 EBCDIC 500 ISO 8859-1 to -10 and -13 to -16 WinOEM 720 UTF-8 MacRoman DEC MCS KOI8-R Western European Eastern European Chinese simplified Chinese traditional Thai		
		Cyrillic Greek Latin Hebrew Arabic	

Fonts			
Bitmap fonts	Widths and heights 1 - 3 mm Zoom factors 2 to 10 Orientations 0°, 90°, 180°, 270°		
Vector / TrueType fonts	Widths and heights 0,9 - 128 mm Variable zoom Orientation 360° in steps of 1°		
Font styles	bold, italic, underlined, outline, inverse - depending from the font types		
Character spacing	variable or monospace for fixed character spacings		
Graphics			
Graphic elements	Lines, arrows, rectangles, circles, ellipses - filled or filled with fading		
Graphic formats	PCX, IMG, BMP, TIF, MAC, GIF, PNG		
Barcodes			
Linear	Code 39, Code 93 Code 39 Full ASCII Code 128 A, B, C EAN 8, 13 EAN/UCC 128/GS1-128 EAN/UPC Appendix 2 EAN/UPC Appendix 5 FIM HIBC	Interleaved 2/5 Ident and routing code of Deutsche Post Codabar JAN 8, 13 MSI Plessey Postnet RSS 14 UPC A, E, E0	
2D and stacked	DataMatrix DataMatrix Rectangle Extension QR code Micro QR code GS1 QR code GS1 DataMatrix PDF 417 Micro PDF 417 UPS MaxiCode GS1 DataBar Aztec Codablock F Dotcode RSS 14 truncated, limited, stacked, stacked omni-directional		
	All codes are variable in terms of height, modular width and ratio; orientations 0°, 90°, 180°, 270° check digit, plain text printout and start / stop code are options depending from the type of code		
Software			
Label software	cablabel S3 Lite cablabel S3 Viewer cablabel S3 Pro cablabel S3 Print		■ ■ □ □
Running also with	CODESOFT NiceLabel BarTender		
Stand-alone operation			■
Windows printer drivers WHQL certified for	Windows Vista Windows 7 Windows 8 Windows 8.1 Windows 10	Server 2008 Server 2008 R2 Server 2012 Server 2012 R2 Server 2016 Server 2019	■
Apple Mac OS X printer drivers	from version 10.6		■
Linux printer drivers	from CUPS 1.2		■
Programming	JScript printer language abc Basic Compiler		■ ■
Integration	SAP Database Connector		■ ■
Emulation	ZPL (Datastream to be tested in advance)		□
Administration	Printer control Configuration in Intranet and Internet Network Manager (in preparation)		■ ■ ■

Label software cablabel S3

Designing, printing, administrating

cablabel S3 opens up the full potential of cab devices. First of all, the label must be designed. cablabel S3 is of a modular design which makes it adaptable to requirements step by step. To support functions like native JScript programming, elements such as the JScript Viewer are embedded as plug-ins. The designer user interface and the JScript code are synchronized in real time. Special functions like the Database Connector or barcode testers can be integrated.



For further information see
www.cab.de/en/cablabe

Stand-alone printing

This operating mode is the printer's ability to select and print labels even when it is not connected to a host system.

The label has to be designed with a software such as cablabel S3 or by direct programming with a text editor on a PC. Label formats, texts, graphics as well as database contents are stored on a memory card, a USB memory stick or in the internal IFFS memory.

Only variable data are sent to the printer via a keyboard, a barcode scanner, scales or other host systems and/or recalled by the Database Connector from the host and printed.



OPC UA

cab printers of the current generation are ready to interact with machines and components of different manufacturers in industrial plants.

An OPC UA server and client is part of the firmware.

The server enables printer configuration and control, while dynamic print data can be prepared via a defined programming interface.

With a client integrated, data fields from other OPC UA-enabled machines can be read and put on the label without the need for an additional software component.



Printer control

Drivers

To control the printer with a software other than cablabel S3, cab provides drivers in 32 / 64 bit for operating systems starting from Windows Vista, Mac OS 10.6 and Linux with CUPS 1.2.

Windows¹⁾ drivers
cab printer drivers are WHQL-certified. They ensure optimum stability on the Windows operating system.

Mac OS X²⁾ drivers
cab provides CUPS-based printer drivers for Mac OS X applications.

Linux³⁾ drivers
Linux drivers are CUPS-based.

Drivers are offered on the DVD delivered with the printer and for free download at www.cab.de/en/support

Programming

JScript
To control the printer, cab has developed the embedded programming language JScript. See manual for free download at www.cab.de/en/programming

abc Basic Compiler
In addition to JScript and as an integral part of the firmware, it allows advanced printer programming before data are sent to printout. For example, external printer languages can be replaced without interfering in the current print job. Also data from other systems such as a scale, a barcode scanner or PLC can be integrated.

Integration

Printer Vendor Program
As a partner in SAP's⁴⁾ Printer Vendor Program, cab has developed a replace method to enable easy control of a cab printer via SAPScript from SAP R/3. Only variable data are sent to the printer by the host. Pictures and fonts that had priorly been stored in the local memory (IFFS, memory card, etc.) are merged.

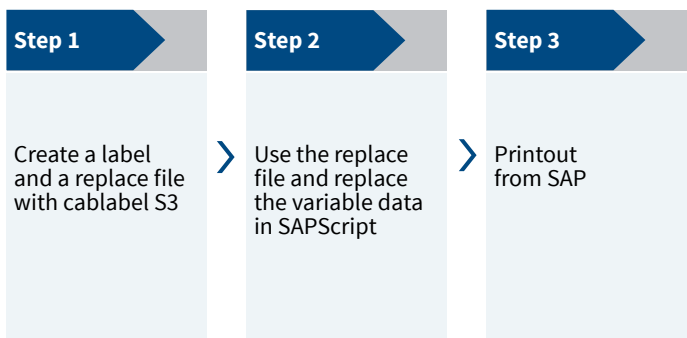

Printer administration

Configuration in Intranet and Internet
The HTTP and FTP server integrated in the printer via standard programs like a web browser or FTP clients allows printer control and configuration, firmware updates and memory card administration. Via email or SNMP, the SNMP and SMTP client datagram sends status, warning and error messages to administrators and users. Time and date are synchronized by a time server.



Network Manager in preparation
It is possible to simultaneously manage several printers within the network. Control, configuration, firmware updates, memory card administration, data synchronization and PIN administration are supported from one single location.



Database Connector
Printers connected to a network may directly access data from a central ODBC or OLEDB-ready database and print it on a label. While printing, data can be rewritten to the database.



¹⁾ Windows is a registered trademark of Microsoft Corporation
²⁾ MAC OS X is a registered trademark of Apple Computer, Inc.
³⁾ for device series SQUIX, MACH 4S, EOS, HERMES Q, PX, PX Q
⁴⁾ SAP and all corresponding logos are trademarks or registered trademarks of SAP SE

Applicators



HERMES Q have been designed for automatic printing and labeling in production lines. Various applicators are provided to roll, blow or tamp labels on products or packaging.

1 Long service life

Precise and low-wear linear guidance by means of a ball bearing chain.

2 Variable product heights

The stroke cylinder allows labeling on different heights. It is available in lengths of 200, 300 and 400 mm as standards. Further lengths can be provided on request.

3 Protective cover

The cylinder and the guide are protected by a cover as standard. Covers adapted to the product jig are offered for labeling workstations.

4 High process reliability

Supporting air, intake air and stroke speed are all to be set. Monitoring is via sensors.

5 Real-time labeling

Applicators transfer small and large labels; Label heights from 4 to 250 mm and label widths from 4 to 174 mm can be processed.



Pressure reducing valve

It reduces the pressure of the stroke cylinder on the product.

6 Applicator, pivoted

Quick and easy access to the print mechanics in cases of material replacement or maintenance.

Overview of applicators and transfer modules

		HERMES Q																	
Applicators		2	4	6.3	Page	11	11	12	61	21	88	32	32	41	51	-	-	90	
		Order code																	
Product marking	Swing applicator	3214	3214		14	-	F	F	F	□	-	-	-	-	-	-	-	-	
	Stroke applicator	4114	4114		15/16	-	F	F	F	□	□	-	-	-	-	-	-	-	
				4116		15/16	-	F	F	F	-	□	-	-	-	-	-	-	
	Stroke turn applicator	4214	4214		17	-	F	F	F	□	-	-	-	-	-	-	-	-	
	Stroke applicator	4414	4414		18	-	F	F	F	-	-	-	-	-	-	-	-	-	
	Swing stroke applicator	4514	4514		19	-	-	-	-	-	□	-	-	-	-	-	-	-	
Flag applicator		4712		20	-	-	-	-	-	-	□	-	-	-	-	-	-		
Package marking	Front side applicator	3014			21	-	□	-	-	□	-	-	□	-	-	-	-	-	
			3016		21	-	□	-	-	-	-	-	□	-	-	-	-	-	
	Stroke applicator	4014			22/23	□	F	-	-	□	-	□	□	□	□	-	-	-	
			4016		22/23	-	□	-	-	-	-	-	□	□	-	-	-	-	
	Stroke blow applicator		4614		24	-	-	-	-	□	-	-	-	-	-	-	-	-	
	Demand module		5114	5116	25	-	-	-	-	-	-	-	-	-	-	□	-	-	
	Vacuum belt applicator		5314	5316	26	-	-	-	-	-	-	-	-	-	-	-	-	□	-
			5414	5416	26	-	-	-	-	-	-	-	-	-	-	-	-	-	□
Air jet box		6114		27	-	-	-	-	-	-	-	-	-	-	-	-	-	□	

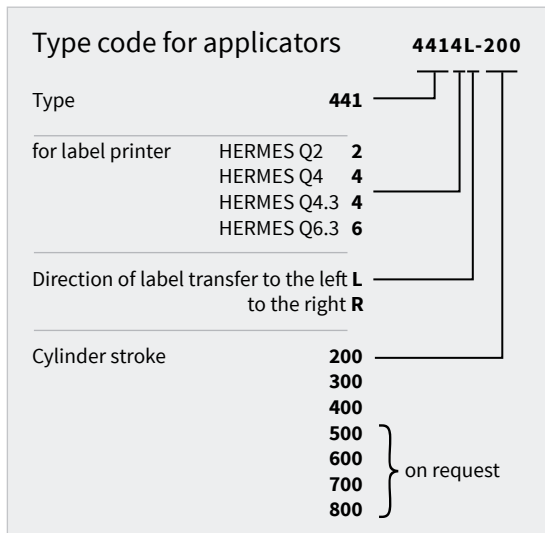
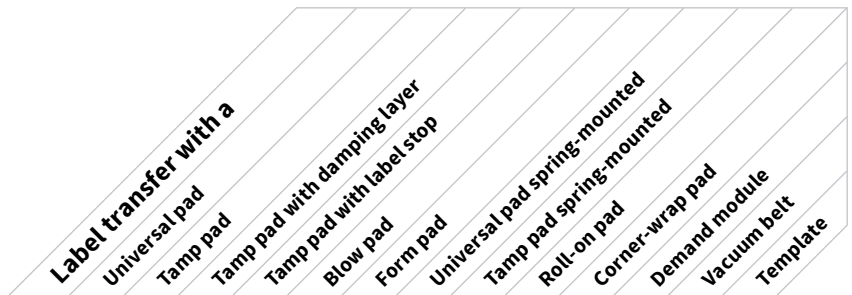

F Allows the tamp pad to immerse into the surface within the label area.

For detailed immersion depths see the applicator's technical data.

In case an applicator's immersion depth succeeds 25 mm, the cover of HERMES Q must be adapted.

Product marking

Swing applicator 3214

The labels are preferably applied on the side of the product.

The pad is positioned in front of the peel-off plate. The label is held during printing. A rotary cylinder swings in labeling position. The stroke cylinder applies the label on the product. Rotary angle and linear stroke are adjustable.

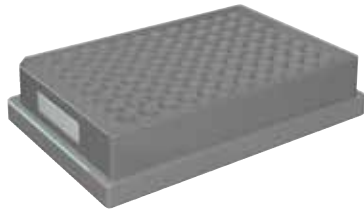

4.1



Accessories

5.13 **Blow tube**

5.14 **Compressed air regulation unit**



Tamp pad

Labels are precisely tamped on plain surfaces, even recessed.

Tamp pad with damping layer

With hard surfaces, the layer contributes to noise damping. The use gives also advantage with rough structures or minor unevenness.

Blow pad

for pressure sensitive surfaces or when products are in motion. Air jet blows the labels onto the product. 5 to 10 mm distance to the product surface are set with a stop on the stroke cylinder.

Tamp pad with label stop

In case of small labels, the stop provides precise positioning on the product.

			Tamp pad	Tamp pad with damping layer	Tamp pad with label stop	Blow pad
Technical data			3214 L/R 11 F	3214 L/R 12 F	3214 L/R 61 F	3214 L/R 2100
Label width	HERMES Q2	mm	4 - 58	10 - 58	10 - 58	10 - 58
	HERMES Q4/Q4.3	mm	10 - 114	10 - 114	10 - 114	10 - 80
Label height	HERMES Q2	mm	5 - 80	8 - 80	5 - 80	10 - 80
	HERMES Q4/Q4.3	mm	8 - 80	8 - 80	8 - 80	10 - 80
Product during labeling	not in motion				■	
	in motion		-	-	-	■
Product labeling	from the side				■	
Product height	fixed				■	
Product distance to peel-off plate	mm			250 - 280		
Horizontal linear guidance	mm			5 - 30		
Pivot angle				45° - 95°		
Immersion depth pad F	up to mm		30	30	30	-
Compressed air	bar			4.5		
Cycle time ¹⁾	approx. labels/min			20		

¹⁾ Calculated with label height 40 mm, print speed 100 mm/s

Product marking

Strike applicators 4114, 4116

for precise real-time labeling of very small to mid-sized labels where installation is difficult. Labeling is possible from all sides.

The pad is positioned in front of the peel-off plate. The label is held during printing. A short stroke cylinder moves the pad horizontally to the labeling position. The stroke cylinder applies the label on the product. The length of the stroke cylinder defines the maximum product distance to the peel-off plate.



Accessories

5.13 Blow tube

5.14 Compressed air regulation unit

5.17 Pressure reducing valve

4.2



Tamp pad

Labels are precisely tamped on plain surfaces, even recessed.

Tamp pad with damping layer

With hard surfaces, the layer contributes to noise damping. The use gives also advantage with rough structures or minor unevenness.

Tamp pad with label stop

In case of small labels, the stop provides precise positioning on the product.

Blow pad

for pressure sensitive surfaces or when products are in motion. Air jet blows the labels onto the product. 5 to 10 mm distance to the product surface are set with a stop on the stroke cylinder.

			Tamp pad	Tamp pad with damping layer	Tamp pad with label stop	Blow pad
Technical data			4114, 4116 L/R 11 F	4114, 4116 L/R 12 F	4114, 4116 L/R 61 F	4114 L/R 2100
Label width	HERMES Q2	mm	4 - 58	10 - 58	10 - 58	10 - 58
	HERMES Q4/Q4.3	mm	10 - 114	10 - 114	10 - 114	10 - 114
	HERMES Q6.3	mm	50 - 174	50 - 174	50 - 174	-
Label height	HERMES Q2	mm	4 - 80	8 - 80	4 - 80	10 - 80
	HERMES Q4/Q4.3	mm	8 - 80	8 - 80	8 - 80	10 - 80
	HERMES Q6.3	mm	8 - 80	8 - 80	8 - 80	-
Product during labeling	not in motion			■		
	in motion		-	-	-	■
Product labeling	from top			■		
	from below			■		
	from the side			■		
Product height	fixed		-	-	-	■
	variable		■	■	■	-
Horizontal short stroke cylinder	mm		10			
Product distance to lower edge of device	at cylinder stroke 200	up to mm	135	135	135	140
	300	up to mm	235	235	235	240
	400	up to mm	335	335	335	340
Immersion depth pad F ¹⁾	up to mm	110	110	110	-	
Compressed air	bar		4.5			
Cycle time ²⁾	approx. labels/min		30			

¹⁾ In case the applicator's immersion depth is more than 25 mm, the cover of HERMES Q has to be adapted.

²⁾ Calculated with stroke 100 mm below device, label height 40 mm, print speed 100 mm/s

Product marking

Stroke applicators 4114, 4116

for precise real-time labeling of very small to mid-sized labels where installation is difficult. Labeling is possible from all sides.

The pad is positioned in front of the peel-off plate. The label is held during printing. A short stroke cylinder moves the pad horizontally to the labeling position. The stroke cylinder applies the label on the product. The length of the stroke cylinder defines the maximum product distance to the peel-off plate.

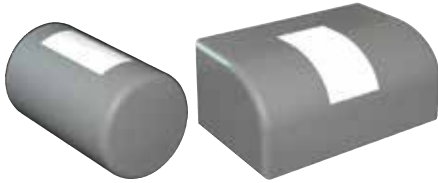

Accessories

5.13 **Blow tube**

5.14 **Compressed air regulation unit**

5.17 **Pressure reducing valve**

4.2



Form pad

Labels are applied precisely to cylindrical objects, oblique or curved surfaces. Curved form pads prevent from bubbling on very smooth and flat surfaces. With cylindrical objects, 200° maximum label wrapping is possible.

Technical data			Form pad
			4114, 4116 L/R 8800
Label width	HERMES Q2	mm	10 - 58
	HERMES Q4/Q4.3	mm	10 - 114
	HERMES Q6.3	mm	50 - 174
Label height		mm	8 - 80
Product during labeling	not in motion		■
Product labeling	from top		■
	from below		■
	from the side		■
Product height	variable		■
Horizontal short stroke cylinder	mm		10
Product distance to lower edge of device			
at cylinder stroke 200	up to mm		135
300	up to mm		235
400	up to mm		335
Compressed air	bar		4.5
Cycle time ¹⁾	approx. labels/min		20

¹⁾ Calculated with stroke 100 mm below the device, label height 40 mm, print speed 100 mm/s
In case the height of the form pad is more than 25 mm, the cover of HERMES Q has to be adapted.

Product marking

Stroke turn applicator 4214

for precise real-time labeling of very small to mid-sized labels where installation is difficult. Labeling is possible from all sides.

The pad is positioned in front of the peel-off plate. The label is held during printing. A rotary cylinder swings the pad horizontally up to 180° in labeling position. The stroke cylinder applies the label on the product. The length of the stroke cylinder defines the maximum product distance to the peel-off plate.



Accessories

5.13 Blow tube

5.14 Compressed air regulation unit

5.17 Pressure reducing valve

4.3



Tamp pad

Labels are precisely tamped on plain surfaces, even recessed.

Tamp pad with damping layer

With hard surfaces, the layer contributes to noise damping. The use gives also advantage with rough structures or minor unevenness.

Blow pad

for pressure sensitive surfaces or when products are in motion. Air jet blows the labels onto the product. 5 to 10 mm distance to the product surface are set with a stop on the stroke cylinder.

Tamp pad with label stop

In case of small labels, the stop provides precise positioning on the product.

			Tamp pad	Tamp pad with damping layer	Tamp pad with label stop	Blow pad
Technical data			4214 L/R 11 F	4214 L/R 12 F	4214 L/R 61 F	4214 L/R 2100
Label width	HERMES Q2	mm	4 - 58	10 - 58	10 - 58	10 - 58
	HERMES Q4/Q4.3	mm	10 - 80			
Label height	HERMES Q2	mm	4 - 40	8 - 40	4 - 40	10 - 40
	HERMES Q4/Q4.3	mm	8 - 40	8 - 40	8 - 40	10 - 40
Product during labeling	not in motion				■	
	in motion		-	-	-	■
Product labeling	from top				■	
	from below				■	
	from the side				■	
Product height	fixed		-	-	-	■
	variable		■	■	■	-
Horizontal rotary angle	90°, 0° 180° with label height up to 15 mm				■	
Product distance to lower edge of device at cylinder stroke	200	up to mm	135	135	135	140
	300	up to mm	235	235	235	240
	400	up to mm	335	335	335	340
Immersion depth pad F ¹⁾	up to mm	65	65	65	-	
Compressed air	bar				4.5	
Cycle time ²⁾	approx. labels/min				20	

¹⁾ In case the applicator's immersion depth is more than 25 mm, the cover of HERMES Q has to be adapted.

²⁾ Calculated with stroke 100 mm below device, label height 40 mm, print speed 100 mm/s

Product marking

Stroke applicator 4414

for very precise real-time labeling of very small to mid-sized labels. Adjustability in x and y directions provides exact positioning on the product. Labeling is possible from all sides.

The pad is positioned in front of the peel-off plate. The label is held during printing. Two short stroke cylinders move the pad horizontally to the labeling position. The stroke cylinder applies the label on the product. The length of the stroke cylinder defines the maximum product distance to the peel-off plate.



Accessories

5.13 **Blow tube**

5.14 **Compressed air regulation unit**

5.17 **Pressure reducing valve**



Tamp pad

Labels are precisely tamped on plain surfaces, even recessed.

4.4



Tamp pad with damping layer

With hard surfaces, the layer contributes to noise damping. The use gives also advantage with rough structures or minor unevenness.

Tamp pad with label stop

In case of small labels, the stop provides precise positioning on the product.

			Tamp pad	Tamp pad with damping layer	Tamp pad with label stop
			4414 L/R 11 F	4414 L/R 12 F	4414 L/R 61 F
Technical data					
Label width	HERMES Q2	mm	4 - 58	10 - 58	10 - 58
	HERMES Q4/Q4.3	mm		10 - 114	
Label height	HERMES Q2	mm	4 - 80	8 - 80	4 - 80
	HERMES Q4/Q4.3	mm		8 - 80	
Product during labeling	not in motion			■	
Product labeling	from top			■	
	from below			■	
	from the side			■	
Product height	variable			■	
Horizontal short stroke cylinder	x direction	mm		3 - 7	
	y direction	mm		11 - 15	
Product distance to lower edge of device					
at cylinder stroke 200	up to	mm		135	
	300	up to		235	
	400	up to		335	
Immersion depth pad F ¹⁾	up to	mm		90	
Compressed air		bar		4.5	
Cycle time ²⁾	approx. labels/min			25	

¹⁾ In case the applicator's immersion depth is more than 25 mm, the cover of HERMES Q has to be adapted.

²⁾ Calculated with stroke 100 mm below device, label height 40 mm, print speed 100 mm/s

Product marking

Swing stroke applicator 4514

for real-time labeling on inner surfaces of profiles and pipes.
The exact position on the product is set with a stop on the stroke cylinder. Labeling is possible from all sides.

The pad is positioned in front of the peel-off plate. The label is held during printing. A rotary cylinder swings the pad to the labeling plane. The stroke cylinder moves the label to the demand position.



Accessories

5.13 Blow tube

5.14 Compressed air regulation unit

4.5



Blow pad

With 5 to 10 mm distance to the product surface, air jet blows the labels onto the product.

Technical data			Blow pad
			4514 L/R 2100
Label width	HERMES Q2	mm	10 - 58
	HERMES Q4/Q4.3	mm	10 - 80
Label height		mm	10 - 60
Product during labeling	not in motion		■
Product labeling	from top		■
	from below		■
	from the side		■
Product height	fixed		■
Vertical pivot angle			120°
Distance lower edge of device to upper edge of label at cylinder stroke	200	up to mm	150 ²⁾
	300	up to mm	250 ²⁾
	400	up to mm	350 ²⁾
Compressed air		bar	4.5
Cycle time ¹⁾	approx. labels/min		20

¹⁾ Calculated with stroke 100 mm below device, label height 40 mm, print speed 100 mm/s

²⁾ depending on the label height

Product marking

Flag applicator 4712

for precise real-time labeling on round materials such as cables, hoses, pipes, etc. Labeling is possible from all sides.

The pad is positioned in front of the peel-off plate. The label is held during printing. It is moved by a stroke cylinder to the demand position. With the other cylinder, the label is guided around the round material via cam control. At first, it is precisely stuck at the ends and only then pressed to the round material. The length of the stroke cylinder defines the maximum product distance to the peel-off plate.

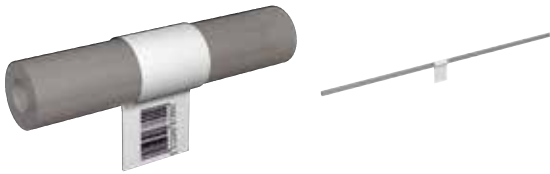

4.6



Accessories

5.13 Blow tube

5.14 Compressed air regulation unit

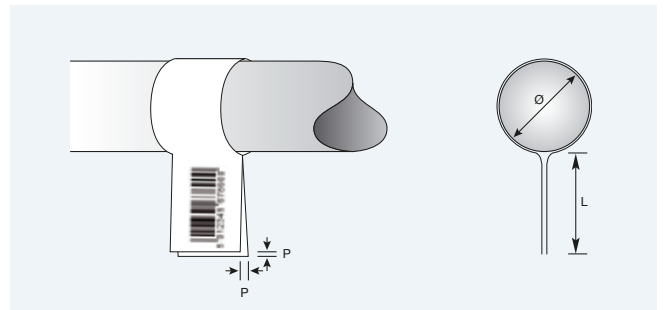
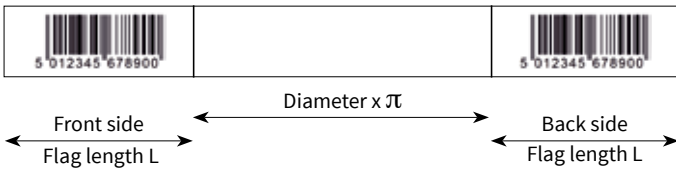

a separate leaflet is in preparation

Technical data		Form pad
		4712 L 300
Label width HERMES Q4L/Q4.3L	mm	60 - 100
Label height	mm	10 - 50
Diameter	mm	3 - 16
Product during labeling	not in motion	■
Product labeling	from top	■
	from below	■
	vertically rotated from the side	0 - 180° clockwise; others on request
Product height	fixed	■
Product distance to lower edge of device min. mm	at cylinder stroke 300	70
	up to mm	260
Immersion depth tongs	mm	55
Offset P	up to mm	1.0 ²⁾
Compressed air	bar	4.5
Cycle time only print and apply ¹⁾ approx. labels/min		15

¹⁾ Calculated with print speed 100 mm/s

²⁾ depending on the label quality

Package marking

Front side applicators 3014, 3016

for real-time labeling on packaging in motion.
The labels are preferably applied to the front or back.
Labeling from top or from the side is possible.

The pad is positioned in front of the peel-off plate. The label is held during printing. The rotary cylinder applies the label on the packaging. A sensor detects the packaging and, when labeling has finished, moves back the pivot arm and pad to their initial position.

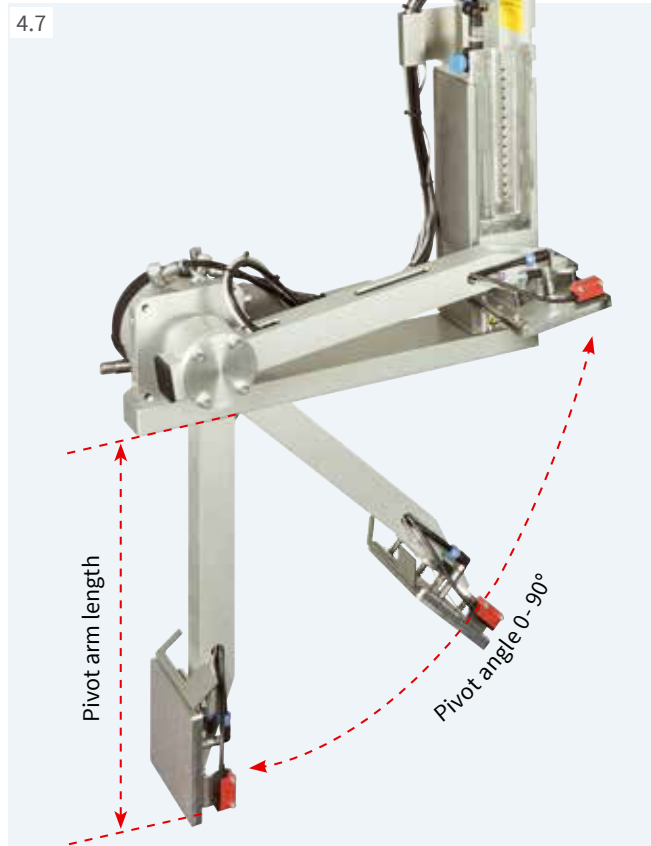

Accessories

5.13 **Blow tube**

5.14 **Compressed air regulation unit**



Tamp pad

Labels are precisely tamped on plain surfaces, even recessed.



Tamp pad spring-mounted

The spring-mounted suction plate allows labeling on inclined surfaces up to 15°. Deviation in height in the area of the label may not exceed 10 mm.



Blow pad

With 5 to 10 mm distance to the product surface, air jet blows the labels onto the product.

Technical data		Tamp pad		Tamp pad spring-mounted	Blow pad
		3014, 3016 L/R 1100		3014, 3016 L/R 3100	3014 L/R 2100
Label width	HERMES Q4/Q4.3	mm	25 - 114	80 - 114	25 - 114
	HERMES Q6.3	mm	25 - 174	80 - 174	-
Label height	HERMES Q4/Q4.3	mm	8 - 250	80 - 250	10 - 100
	HERMES Q6.3	mm	25 - 250	80 - 250	25 - 100
Product during labeling	not in motion		■		
	in motion		■		
Product labeling	from top		■		
	from the side		■		
	from the front		■		
	from the back		■		
Product height	variable		■		
Pivot arm length ¹⁾	mm			200 / 300 / 400	
Pivot angle				0 - 90°	
Compressed air	bar			4.5	
Cycle time ²⁾	approx. labels/min			15	

¹⁾ Pivot arm length is defined as the accessible 90° label position (lower edge of the label) below the footprint of HERMES Q.

²⁾ Calculated with pivot arm length 200 mm, label height 100 mm, print speed 100 mm/s

Package marking

Stroke applicators 4014, 4016

for real-time labeling on packaging or products. Depending on the type of pad, the product is either in motion or not in motion during labeling. Labeling is possible from all sides.

The pad is positioned in front of the peel-off plate. The label is held during printing. The stroke cylinder applies the label on the product. A sensor detects the product and moves back the pad to its initial position. The length of the stroke cylinder defines the maximum product distance to the peel-off plate.



Accessories

5.13 **Blow tube**

5.14 **Compressed air regulation unit**

5.17 **Pressure reducing valve**

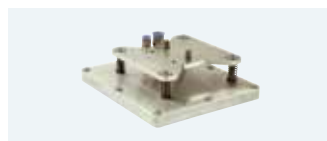

Tamp pad

Labels are precisely tamped on plain surfaces, even recessed.

Universal pad

Labels are tamped on plain surfaces. Holes to suck the labels are pre-drilled in gaps of 5 mm and are covered by a sliding foil. They are opened with a punching tool, according to the label size. Delivery includes two foils for substitution.

Tamp pad spring-mounted

The spring-mounted suction plate allows labeling on inclined surfaces up to 15°. Deviation in height in the area of the label may not exceed 10 mm.

Universal pad spring-mounted

The spring-mounted suction plate allows labeling on inclined surfaces up to 15°. Deviation in height in the area of the label may not exceed 10 mm. Holes to suck the labels are pre-drilled in gaps of 5 mm and are covered by a sliding foil. Delivery includes two foils for substitution.

4.8



			Tamp pad	Universal pad	Tamp pad spring-mounted	Universal pad spring-mounted
Technical data			4014, 4016 L/R 11 F	4014 L/R 1100	4014, 4016 L/R 3100	4014 L/R 3100
Label width	HERMES Q4/Q4.3	mm	20 - 114	75 / 90	80 - 114	116 / 116
	HERMES Q6.3	mm	50 - 174	-	80 - 174	-
Label height	HERMES Q4/Q4.3	mm	20 - 210	60 / 90	80 - 210	102 / 152
	HERMES Q6.3	mm	25 - 210	-	80 - 210	-
Product during labeling	not in motion				■	
Product labeling	from top				■	
	from below				■	
	from the side				■	
Product height	variable				■	
Product distance to lower edge of device at cylinder stroke 200	up to mm		135	135	130	130
	300	up to mm	235	235	230	230
	400	up to mm	335	335	330	330
Immersion depth pad F ¹⁾	up to mm		120	-	-	-
Compressed air	bar				4.5	
Cycle time ²⁾	approx. labels/min				25	

¹⁾ In case the applicator's immersion depth is more than 25 mm, the cover of HERMES Q has to be adapted.

²⁾ Calculated with stroke 100 mm below device, label height 100 mm, print speed 100 mm/s

Package marking

Stroke applicators 4014, 4016

for real-time labeling on packaging or products. Depending on the type of pad, the product is either in motion or not in motion during labeling. Labeling is possible from all sides.

The pad is positioned in front of the peel-off plate. The label is held during printing. The stroke cylinder applies the label on the product. A sensor detects the product and moves back the pad to its initial position. The length of the stroke cylinder defines the maximum product distance to the peel-off plate.

4.8



Accessories

5.13 Blow tube

5.14 Compressed air regulation unit

5.17 Pressure reducing valve



Blow pad

for pressure sensitive surfaces or when products are in motion. Air jet blows the labels onto the product. 5 to 10 mm distance to the product surface are set with a stop on the stroke cylinder.

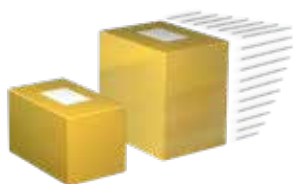

Roll-on pad

Labels are rolled on plain surfaces of the product during transport.



Corner-wrap pad

Labels are attached on two adjacent sides of the product. Half of the label is applied by the pad on the top side. Then the second half of the label is rolled on.

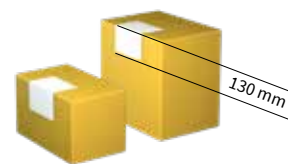

Technical data			Blow pad	Roll-on pad	Corner-wrap pad
			4014 L/R 2100	4014, 4016 L/R 4100	4014 L/R 5100
Label width	HERMES Q4/Q4.3	mm	20 - 114	25 - 114	20 - 114
	HERMES Q6.3	mm	on request	50 - 174	-
Label height	HERMES Q4/Q4.3	mm	20 - 100	80 - 250	60 - 210
	HERMES Q6.3	mm	on request	80 - 250	-
Product during labeling	not in motion		■	-	■
	in motion		■	■	-
Product labeling	from top			■	
	from below		■	■	-
	from the side		■	■	-
Product height	fixed		■	-	-
	variable		-	■	■
Product distance to lower edge of device	at cylinder stroke 200	up to mm	140	160	100
	300	up to mm	240	260	200
	400	up to mm	340	360	300
Compressed air		bar		4.5	
Cycle time ¹⁾	approx. labels/min		25	20	20

¹⁾ Calculated with stroke 100 mm below device, label height 100 mm, print speed 100 mm/s

Package marking

Stroke blow applicator 4614

for real-time labeling of packaging of different heights in motion. Labeling is possible from all sides.

The pad is positioned in front of the peel-off plate. The label is held during printing. Sensor controlled, the stroke cylinder moves the pad to a position approximately 10 mm above the packaging. The length of the stroke cylinder defines the maximum differences in height of the packages.



Accessories

5.13 **Blow tube**

5.14 **Compressed air regulation unit**

4.9



Blow pad

With 5 to 10 mm distance to the product surface, air jet blows the labels onto the product.

Technical data			Blow pad 4614 L/R 2100
Label width	HERMES Q4/Q4.3	mm	20 - 114
	HERMES Q6.3	mm	on request
Label height	HERMES Q4/Q4.3	mm	20 - 100
	HERMES Q6.3	mm	on request
Product during labeling	not in motion		■
	in motion		■
Product labeling	from top		■
	from below		■
	from the side		■
Product height	fixed		■
	variable		■
Product distance to lower edge of device at cylinder stroke	200	up to mm	140
	300	up to mm	240
	400	up to mm	340
Compressed air		bar	4.5
Cycle time ¹⁾	approx. labels/min		25

¹⁾ Calculated with cylinder stroke 100 mm below device, label height 100 mm, print speed 100 mm/s

Package marking

Demand module 5114/5116

for serial labeling of packaging in motion. The label position on the peel-off tongue is adjusted with the adjustable rewind assist roller. Labeling is possible from all sides.

During labeling, the next label is printed simultaneously. The conveyor belt speed has to be adapted to the print speed.

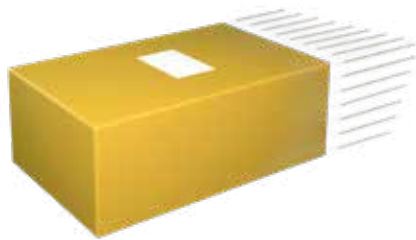

1 Draw roller
A steel roller is required on demand modules.

Technical data			Demand module	
			5114 L/R	5116 L/R
Label width	HERMES Q4/Q4.3	mm	25 - 114	-
	HERMES Q6.3	mm	-	46 - 174
Label height		mm	25 - 250	
Print line distance to peel-off plate		mm	400 - 600	
Product during labeling		in motion	■	
Product labeling		from top	■	
		from below	■	
		from the side	■	
Product height		fixed	■	
Product distance to lower edge of device		mm	80	
Product speed		mm/s	must correspond to the print speed / 50 - 250 in steps of 25	
Cycle time ¹⁾		approx. labels/min	60	

¹⁾ Calculated with label height 100 mm, print speed 100 mm/s

Package marking

Vacuum belt applicators 5314, 5316, 5414, 5416

for real-time labeling on packaging or products in motion. Labeling is possible from all sides on plain surfaces, cylinders resp. corner-wrap.

The vacuum belt applicator is positioned in front of the peel-off plate. The printed label is transferred by the vacuum conveyor belt to the demand position and labeled on the packaging by an external signal.

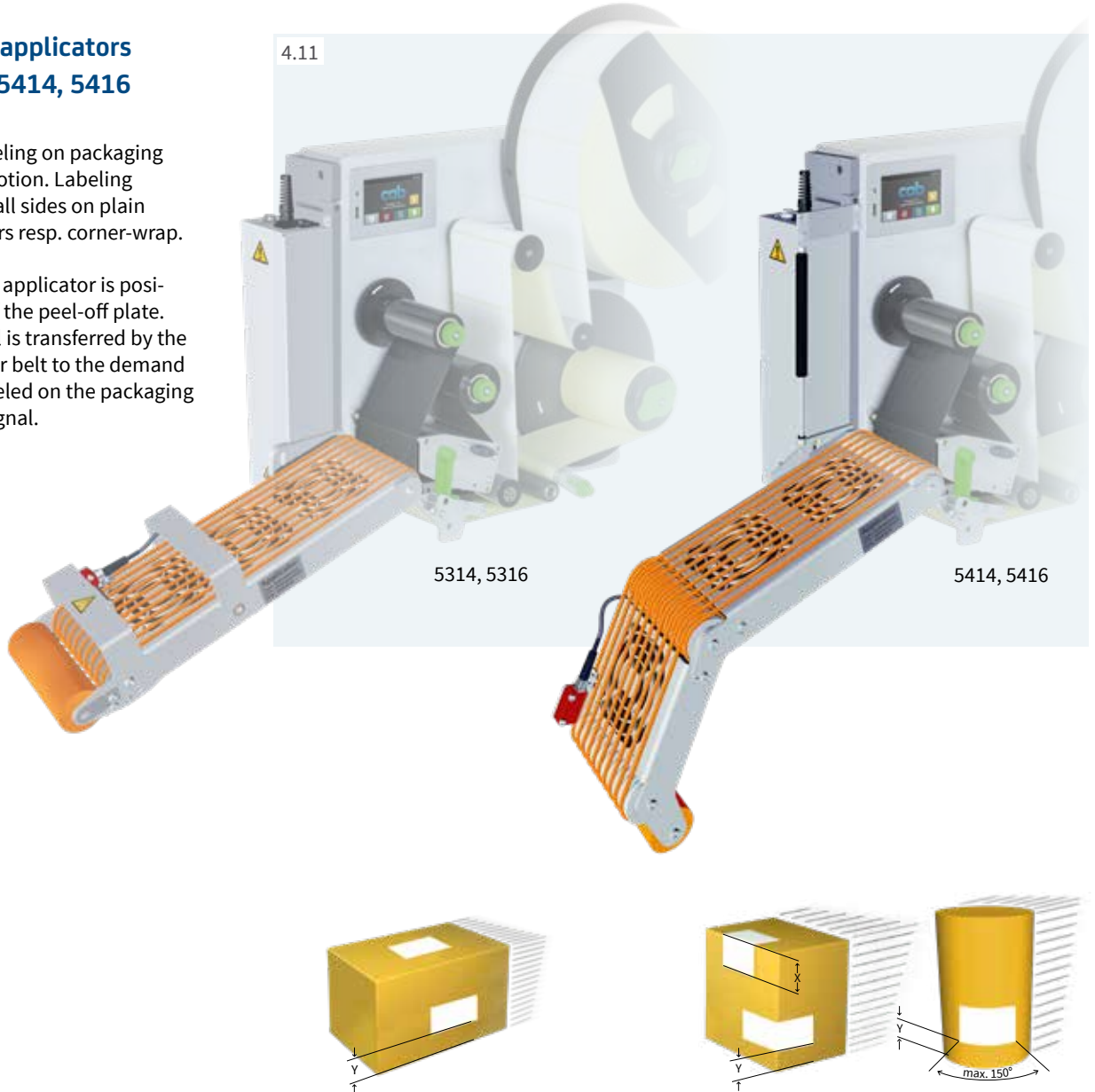

			Vacuum belt applicator			
Technical data			5314-3	5316-3	5414-3	5416-3
Labeling			on the surface		on the surface, a cylinder or corner-wrap	
Direction of label demand			left and right			
Label width	HERMES Q4/Q4.3	mm	20 - 114	-	20 - 114	-
	HERMES Q6.3	mm	-	46 - 174	-	46 - 174
Label height		mm	60 - 356	60 - 356	80 - 356	80 - 356
Product during labeling		in motion			■	
Product labeling		from top			■	
		from below	■	■	-	-
		from the side			■	
Product height		fixed		■		■
		variable		-		■
Product speed		up to m/s	0.5	0.5	0.3	0.3
Gap between products		min. m	0.5			
Stability on application level			-	-	F ¹⁾ = 30 N	F ¹⁾ = 30 N
Corner-wrap labeling		up to mm	-	-	dimension X = 160	dimension X = 160
Vacuum conveyor belt speed ²⁾		mm/s	100 - 500	100 - 500	100 - 300	100 - 300
Cycle time ³⁾		up to labels/min	30	30	15	15
Label distance to conveyor belt when labeling from the side		mm	dimension Y = 20			

¹⁾ F = force required to swing the vacuum conveyor belt

²⁾ The product speed must be equal or higher than the vacuum conveyor belt speed.

³⁾ Calculated with label height 100 mm, print speed 250 mm/s

Package marking

Air jet box 6114

for fast labeling in motion or not in motion. The labels are sucked by a fan and blown off by a powerful blast of air through aligned nozzles. The maximum distance from the packaging to the peel-off plate is 200 mm, depending on the label size.

Accessories

5.13 Blow tube

5.16 Compressed air regulation unit with a shut-off valve

for fully venting the hose lines beyond the compressed air regulation unit. Left hand or right hand versions are provided.



1 Template

to cover the suction and air jet holes around the label

It is pre-scored in a hole pattern of 8 x 8 mm and can be easily adapted to the label size. By sliding in between the suction block and the slide bars, the area around the label is covered. Five templates are included in the scope of delivery.

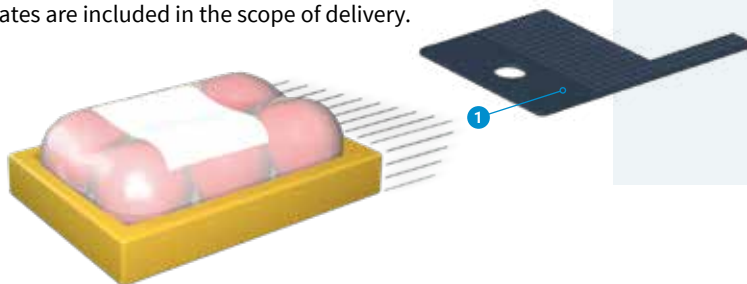

4.12



Technical data		Air jet box
		6114 L/R
Label width HERMES Q4/Q4.3	mm	50-114 smaller sizes on request
Label height	mm	50-125 smaller sizes on request
Product during labeling	not in motion	■
	in motion	■
Product labeling	from top	■
	from below	■
	from the side	■
Product height	variable	■
Product distance to peel-off plate	up to mm	200
Compressed air	bar	4.5 - 6
Cycle time ¹⁾	up to labels/min	100

¹⁾ Calculated with label height 50 mm, print speed 250 mm/s, blowing time 100 ms and a distance of 100 mm from the product to the peel-off plate



Overview of accessories

■ standard □ option

Pos.	HERMES Q accessories	1.1	1.2		1.3
		HERMES Q2	HERMES Q4.3	HERMES Q4	HERMES Q6.3
2.1	SD memory card 8 GB	<input type="checkbox"/>	<input type="checkbox"/>	<input type="checkbox"/>	<input type="checkbox"/>
2.2	USB memory stick 8 GB	<input type="checkbox"/>	<input type="checkbox"/>	<input type="checkbox"/>	<input type="checkbox"/>
2.3	USB WLAN stick	<input type="checkbox"/>	<input type="checkbox"/>	<input type="checkbox"/>	<input type="checkbox"/>
2.4	USB WLAN stick with a rod antenna	<input type="checkbox"/>	<input type="checkbox"/>	<input type="checkbox"/>	<input type="checkbox"/>
2.5	USB Bluetooth adapter	<input type="checkbox"/>	<input type="checkbox"/>	<input type="checkbox"/>	<input type="checkbox"/>
2.6	Product sensor, 3 pin	-	<input type="checkbox"/>	<input type="checkbox"/>	-
2.7	Product sensor, 25 pin	<input type="checkbox"/>	<input type="checkbox"/>	<input type="checkbox"/>	<input type="checkbox"/>
2.8	2-Port Ethernet Switch 10/100 Mbit/s	<input type="checkbox"/>	<input type="checkbox"/>	<input type="checkbox"/>	<input type="checkbox"/>
2.9	I/O interface connector SUB-D, 25 pin	<input type="checkbox"/>	<input type="checkbox"/>	<input type="checkbox"/>	<input type="checkbox"/>
2.10	Warning light	<input type="checkbox"/>	<input type="checkbox"/>	<input type="checkbox"/>	<input type="checkbox"/>
2.11	Print rollers DRS	<input type="checkbox"/>	<input type="checkbox"/>	<input type="checkbox"/>	<input type="checkbox"/>
2.12	Draw roller	-	<input type="checkbox"/>	<input type="checkbox"/>	<input type="checkbox"/>
2.13	Spacers	<input type="checkbox"/>	<input type="checkbox"/>	<input type="checkbox"/>	-
2.14	Antistatic brush	<input type="checkbox"/>	<input type="checkbox"/>	<input type="checkbox"/>	-
2.15	Margin stop	<input type="checkbox"/>	<input type="checkbox"/>	<input type="checkbox"/>	<input type="checkbox"/>
2.16	External operation panel	<input type="checkbox"/>	<input type="checkbox"/>	<input type="checkbox"/>	<input type="checkbox"/>
	Connecting cable USB	<input type="checkbox"/>	<input type="checkbox"/>	<input type="checkbox"/>	<input type="checkbox"/>
2.17	Label selection - I/O box	<input type="checkbox"/>	<input type="checkbox"/>	<input type="checkbox"/>	<input type="checkbox"/>
2.18	Hand switch TR2	<input type="checkbox"/>	<input type="checkbox"/>	<input type="checkbox"/>	<input type="checkbox"/>
2.19	Foot switch	<input type="checkbox"/>	<input type="checkbox"/>	<input type="checkbox"/>	<input type="checkbox"/>
2.20	Connecting cable RS232 C	<input type="checkbox"/>	<input type="checkbox"/>	<input type="checkbox"/>	<input type="checkbox"/>
2.21	Barcode tester CC200	<input type="checkbox"/>	<input type="checkbox"/>	<input type="checkbox"/>	<input type="checkbox"/>
Options (assembly ex factory)					
3.1	Cover	<input type="checkbox"/>	<input type="checkbox"/>	<input type="checkbox"/>	<input type="checkbox"/>
3.2	Extended peel-off plate +10 mm	<input type="checkbox"/>	<input type="checkbox"/>	<input type="checkbox"/>	<input type="checkbox"/>
Assembly aids					
6.1	Adapter plate	<input type="checkbox"/>	<input type="checkbox"/>	<input type="checkbox"/>	<input type="checkbox"/>
6.2	Profiles 40, 80, 120 mm	<input type="checkbox"/>	<input type="checkbox"/>	<input type="checkbox"/>	<input type="checkbox"/>
6.3	Base plate 500 x 255 mm	<input type="checkbox"/>	<input type="checkbox"/>	<input type="checkbox"/>	-
6.4	Mounting plate	<input type="checkbox"/>	<input type="checkbox"/>	<input type="checkbox"/>	<input type="checkbox"/>
6.5	Bracket	<input type="checkbox"/>	<input type="checkbox"/>	<input type="checkbox"/>	<input type="checkbox"/>
6.6	Clamped joint for profile 50 x 50 mm	<input type="checkbox"/>	<input type="checkbox"/>	<input type="checkbox"/>	<input type="checkbox"/>
6.7	Flanged joint for profile 50 x 50 mm	<input type="checkbox"/>	<input type="checkbox"/>	<input type="checkbox"/>	<input type="checkbox"/>
6.8	Floor stand 1601	<input type="checkbox"/>	<input type="checkbox"/>	<input type="checkbox"/>	<input type="checkbox"/>
6.9	Floor stand 1602	<input type="checkbox"/>	<input type="checkbox"/>	<input type="checkbox"/>	<input type="checkbox"/>

Pos.	Applicator accessories	4.1	4.2	4.3	4.4	4.5	4.6	4.7	4.8	4.9	4.12
		3214	4114 4116	4214	4414	4514	4712	3014 3016	4014 4016	4614	6114
5.13	Blow tube	■	■	■	■	■	■	■	■	■	■
5.14	Compr. air regulation unit	<input type="checkbox"/>	<input type="checkbox"/>	<input type="checkbox"/>	<input type="checkbox"/>	<input type="checkbox"/>	<input type="checkbox"/>	<input type="checkbox"/>	<input type="checkbox"/>	<input type="checkbox"/>	<input type="checkbox"/>
5.17	Pressure reducing valve	-	<input type="checkbox"/>	<input type="checkbox"/>	<input type="checkbox"/>	-	-	-	<input type="checkbox"/>	-	-

HERMES Q accessories

2.1		SD memory card 8 GB		2.11		Print rollers DRS Coating: silicone They have an extra long service life at a higher imprint tolerance.	
2.2		USB memory stick 8 GB		2.12		Draw roller If labels exceed 150 mm in height, are peeled off without backfeed or applied by demand modules 5114/16, steel rollers are required.	
2.3		USB WLAN stick 2.4 GHz 802.11b/g/n Hotspot or Infrastructure Mode		2.13		Spacers refit kit for small materials	
2.4		USB WLAN stick with a rod antenna for extended reach 2.4 GHz 802.11b/g/n + 5 GHz 802.11a/n/ac Hotspot or Infrastructure Mode		2.14		Antistatic brush Particularly with plastic materials the electrostatic charge is discharged after printing. With extended peel-off plate only.	
2.5		USB Bluetooth adapter		2.15		Margin stop to guide 10 to 24 mm wide label rolls	
2.6		Product sensor, 3 pin to connect a front side applicator, vacuum belt applicator or air jet box. In case a product has been detached, e.g. on a conveyor belt, labeling is started.		2.16		External operation panel If the operation panel is not accessible after printer installation, an external one can be additionally connected.	
2.7		Product sensor, 25 pin In case a product has been detached, e.g. on a conveyor belt, labeling is started.				Connecting cable USB , length 1.8 m Connecting cable USB , length 3 m Connecting cable USB , length 5 m Connecting cable USB , length 11 m Connecting cable USB , length 16 m	
2.8		2-Port Ethernet Switch 10/100 Mbit/s		2.17		Label selection - I/O box Up to 16 different labels can be selected from a memory card by a master control, e.g. PLC.	
2.9		I/O interface connector SUB-D, 25 pin with clamping screws to connect all control signals to the I/O interface		2.18		Hand switch TR2 on the I/O interface	
2.10		Warning light In addition to the display, it indicates the printer status. Red Collective error Yellow Pre-warning to labels and ribbon ending Green Device ready Delivery includes a connecting cable and material to assemble to the chassis or a bracket. USB connection to HERMES Q Connecting cable, length 1 m ① Assembly to the chassis ② Assembly to the bracket		2.19		Foot switch on the I/O interface	
				2.20		Connecting cable RS232 C 9/9 pin, length 3 m	
				2.21		Barcode tester CC200 on request	
Options (assembly ex factory)							
				3.1		Cover suitable for label roll outside diameters up to 205 mm. It protects from dirt and contact. In case the applicator's immersion depth succeeds 25 mm, the cover must be adapted. Approved for vertical assembly or when the system has to be installed lying on its back.	
				3.2		Extended peel-off plate in case labels are hard to remove	

HERMES Q assembly aids



Mounting foot
 to install HERMES Q on a desk or in a production line;
 provided as left hand and right hand versions
 The size of the mounting foot can be adapted to the application.

- 1 **Adapter plate**
 The labeling system is assembled to the adapter plate.
 It may also be assembled with the adapter plate to the profile directly in the production line.
- 2 **Profile**
 Aluminum square profile, standard lengths are 40, 80, 120 mm;
 customized lengths are possible
- 3 **Base plate**
 to assemble the product holder; standard size is 500 x 255 mm

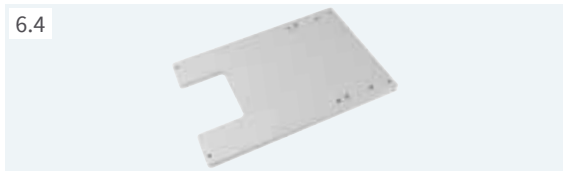

Mounting plate
 to assemble HERMES Q directly in a production line



Bracket
 to assemble HERMES Q to a floor stand

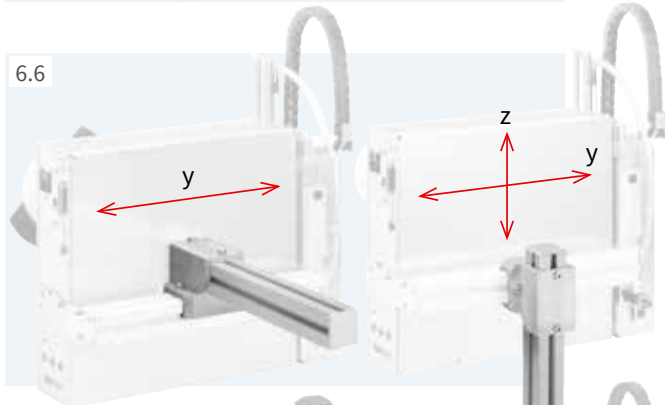

Clamped joint for profile 50 x 50 mm
 to move the labeling system horizontally and vertically

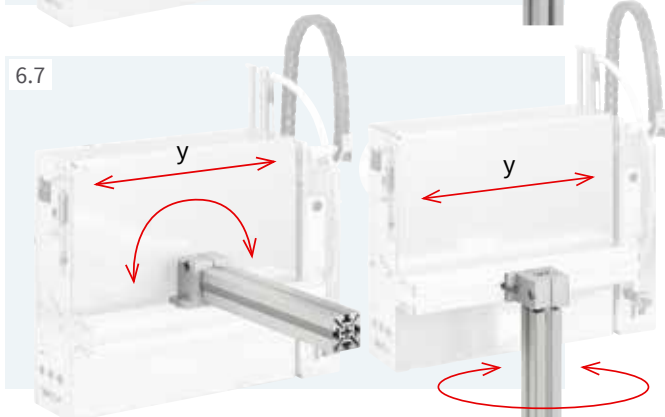

Flanged joint for profile 50 x 50 mm
 to move the labeling system horizontally or rotate around an axis

HERMES Q floor stands

To install HERMES Q in a production line. With the help of adjustment options, it can be set in three axes to the product that has to be labeled. Pivoting is also possible.

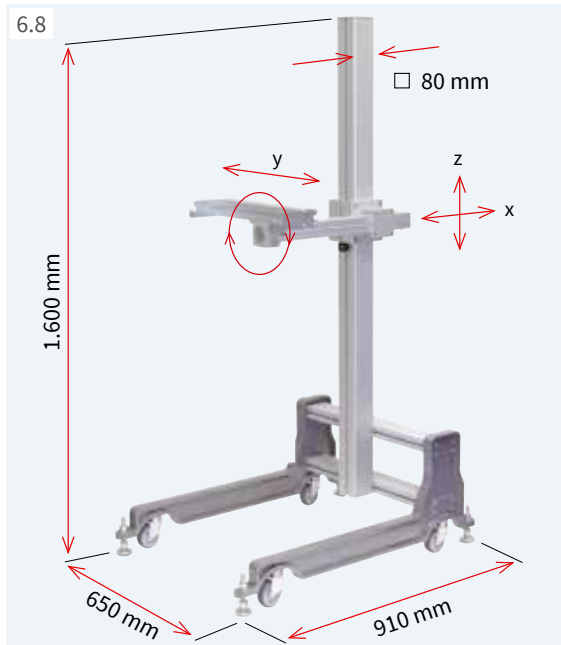

Floor stand 1601

Preferred use is with applications in different production lines. The mobile floor stand can be aligned with adjustable feet at the place of application.

		Floor stand
		1601
Technical data		
Base frame		Castors, adjustable feet
Height and depth setting		Screw clamping
Load in case of 500 mm offset	up to kg	50
Weight	kg	36

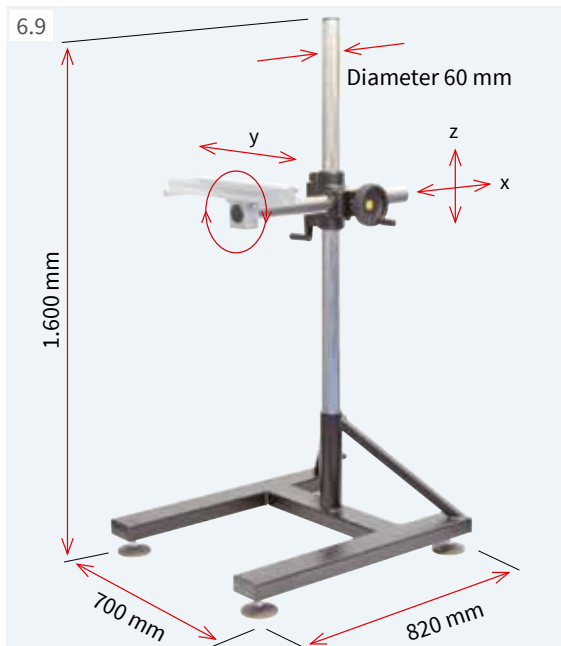

Floor stand 1602

Preferred use is with applications in which the heights and depths of the labeling position have to be changed frequently. With the help of the toothed rack construction, HERMES Q can be set in directions x and z to the product.

		Floor stand
		1602
Technical data		
Base frame		Adjustable feet
Height setting		Toothed rack / crank
Depth setting		Toothed rack / handwheel
Load in case of 500 mm offset	up to kg	50
Weight	kg	38

Examples of how to assemble to a stand

Labeling in direction of transport from top

from the side

Labeling crosswise the direction of transport from top

from the side

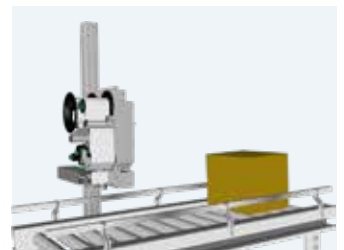
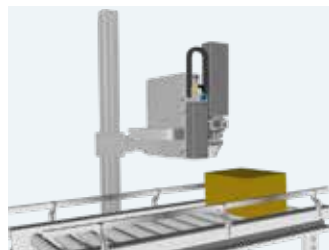
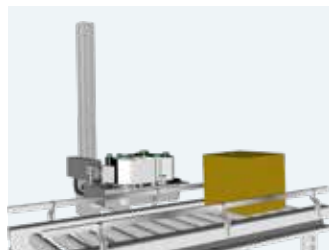
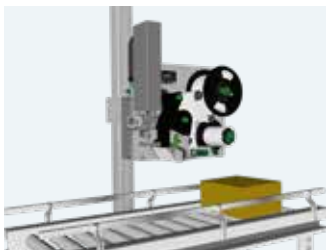

Applicator accessories

5.13



Blow tube

supporting air. To assist the label transfer, the label is blown from below to the pad.

Provided for 2", 4" or 6" label applications

5.14



Compressed air regulation unit

for compressed air preparation; 4.5 bar default setting

Left hand or right hand versions are provided.

Delivery includes a fine filter, pressure control valve, pressure display, a hose to be connected to the applicator's compressed air input and material to assemble to the chassis or bracket.

5.16



Compressed air regulation unit with a shut-off valve provided for the air jet box 6114

for fully venting the hose lines beyond the compressed air regulation unit. Left hand or right hand versions are provided.

5.17



Pressure reducing valve

to reduce the pressure of the stroke cylinder contacting the product

For applicators 4014/4016, 4114/4116, 4214, 4414

Examples of how to assemble a compressed air regulation unit

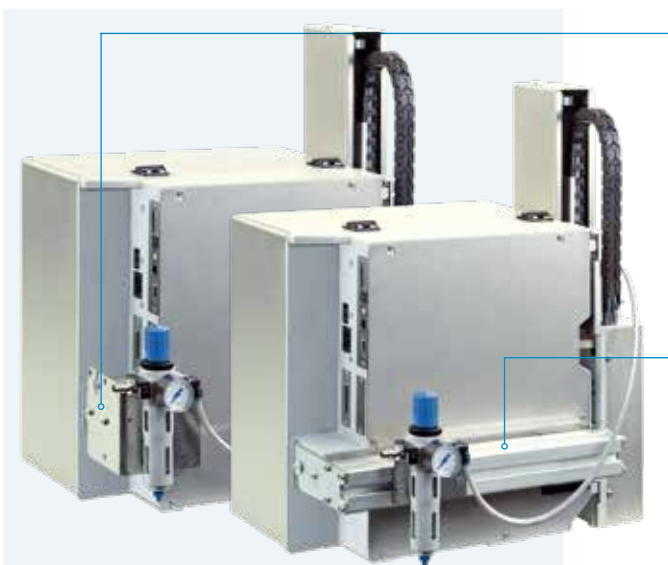

Regulation unit assembly
with material to attach to the chassis

Regulation unit assembly
with material to attach to the bracket

Delivery program HERMES Q

Pos.	Part no.	Label printers L	Part no.	Print heads	dpi	Part no.	Print rollers	Part no.	Draw rollers
1.1	6010003	Label printer HERMES Q2L/300-2	5977384.001	Print head 2	300	5954102.001	Print roller DR2	5961015.001	Draw roller ZR2
	6010004	Label printer HERMES Q2L/600-2	5977385.001	Print head 2	600				
1.2	6010005	Label printer HERMES Q4L/300-2	5977444.001	Print head 4	300	5954180.001	Print roller DR4	5961298.001	Draw roller ZR4
	6010006	Label printer HERMES Q4L/600-2	5977380.001	Print head 4	600				
	6010007	Label printer HERMES Q4.3L/200-2	5977382.001	Print head 4.3	200				
	6010008	Label printer HERMES Q4.3L/300-2	5977383.001	Print head 4.3	300				
1.3	6010009	Label printer HERMES Q6.3L/200-2	5977386.001	Print head 6.3	200	5954245.001	Print roller DR6	5961220.001	Draw roller ZR6
	6010010	Label printer HERMES Q6.3L/300-2	5977387.001	Print head 6.3	300				
1.1	6010011	Label printer HERMES Q2L/300-3	5977384.001	Print head 2	300	5954102.001	Print roller DR2	5961015.001	Draw roller ZR2
	6010012	Label printer HERMES Q2L/600-3	5977385.001	Print head 2	600				
1.2	6010013	Label printer HERMES Q4L/300-3	5977444.001	Print head 4	300	5954180.001	Print roller DR4	5961298.001	Draw roller ZR4
	6010014	Label printer HERMES Q4L/600-3	5977380.001	Print head 4	600				
	6010015	Label printer HERMES Q4.3L/200-3	5977382.001	Print head 4.3	200				
	6010016	Label printer HERMES Q4.3L/300-3	5977383.001	Print head 4.3	300				
1.3	6010017	Label printer HERMES Q6.3L/200-3	5977386.001	Print head 6.3	200	5954245.001	Print roller DR6	5961220.001	Draw roller ZR6
	6010018	Label printer HERMES Q6.3L/300-3	5977387.001	Print head 6.3	300				
Pos.	Part no.	Label printers L	Part no.	Print heads	dpi	Part no.	Print rollers	Part no.	Draw rollers
1.1	6010023	Label printer HERMES Q2R/300-2	5977384.001	Print head 2	300	5954102.001	Print roller DR2	5961015.001	Draw roller ZR2
	6010024	Label printer HERMES Q2R/600-2	5977385.001	Print head 2	600				
1.2	6010025	Label printer HERMES Q4R/300-2	5977444.001	Print head 4	300	5954180.001	Print roller DR4	5961298.001	Draw roller ZR4
	6010026	Label printer HERMES Q4R/600-2	5977380.001	Print head 4	600				
	6010027	Label printer HERMES Q4.3R/200-2	5977382.001	Print head 4.3	200				
	6010028	Label printer HERMES Q4.3R/300-2	5977383.001	Print head 4.3	300				
1.3	6010029	Label printer HERMES Q6.3R/200-2	5977386.001	Print head 6.3	200	5954245.001	Print roller DR6	5961220.001	Draw roller ZR6
	6010030	Label printer HERMES Q6.3R/300-2	5977387.001	Print head 6.3	300				
1.1	6010031	Label printer HERMES Q2R/300-3	5977384.001	Print head 2	300	5954102.001	Print roller DR2	5961015.001	Draw roller ZR2
	6010032	Label printer HERMES Q2R/600-3	5977385.001	Print head 2	600				
1.2	6010033	Label printer HERMES Q4R/300-3	5977444.001	Print head 4	300	5954180.001	Print roller DR4	5961298.001	Draw roller ZR4
	6010034	Label printer HERMES Q4R/600-3	5977380.001	Print head 4	600				
	6010035	Label printer HERMES Q4.3R/200-3	5977382.001	Print head 4.3	200				
	6010036	Label printer HERMES Q4.3R/300-3	5977383.001	Print head 4.3	300				
1.3	6010037	Label printer HERMES Q6.3R/200-3	5977386.001	Print head 6.3	200	5954245.001	Print roller DR6	5961220.001	Draw roller ZR6
	6010038	Label printer HERMES Q6.3R/300-3	5977387.001	Print head 6.3	300				

	Part no.	Label printers with options
	xxxxxxx.201	Label printer HERMES Q with a cover suitable for label roll diameters up to 205 mm
	xxxxxxx.202	Label printers HERMES Q4/Q4.3 and HERMES Q6.3 with automatic saving
	xxxxxxx.203	Label printers HERMES Q4/Q4.3 and HERMES Q6.3 with a cover and automatic saving suitable for label roll diameters up to 205 mm
L	6010586	Spacers assembled to HERMES Q2/ Q4/Q4.3
R	6010590	
	5961751	Draw roller ZU4 assembled to HERMES Q4/Q4.3
	5961752	Draw roller ZU6 assembled to HERMES Q6.3
L	6010557	Extended peel-off plate assembled to HERMES Q2
R	6010563	
L	6010558	Extended peel-off plate assembled to HERMES Q4/Q4.3
R	6010564	
L	6010559	Extended peel-off plate assembled to HERMES Q6.3
R	6010565	
L	5961640	Antistatic brush assembled to HERMES Q2
R	5961642	
L	5961644	Antistatic brush assembled to HERMES Q4/Q4.3
R	5961646	

Multiple options may be assembled to a device simultaneously.

Scope of delivery

Label printer HERMES Q
Power cable Type E+F, length 1.8 m
Connecting cable USB, length 1.8 m
Assembly instructions DE/EN

DVD:

Assembly instructions DE/EN/FR
Configuration manual DE/EN/FR
Service manual DE/EN
Spare parts list DE/EN
Programming manual EN
WHQL certified Windows printer drivers for
Windows Vista Server 2008
Windows 7 Server 2008 R2
Windows 8 Server 2012
Windows 8.1 Server 2012 R2
Windows 10 Server 2016
Server 2019























Apple Mac OS X printer drivers DE/EN/FR
Linux printer drivers DE/EN/FR
Label software cablabel S3 Lite
cablabel S3 Viewer
Database Connector

Scopes of delivery, design and technical specifications correspond to the date of the printing. Subject to change. The data provided in the catalog do not represent any warranty or guarantee.













Information is also available on the Internet:
www.cab.de/en/hermesq

Delivery program of applicators L

Pos.	Part no.	Applicators L	Part no.	Transfer modules
4.1	 5970075	Swing applicator 3214L-40	xxxxxxx xxxxxxx xxxxxxx xxxxxxx	Tamp pad Tamp pad with damping layer Tamp pad with label stop Blow pad 3214L-11 F W x H 3214L-12 F W x H 3214L-61 F W x H 3214L-2100 W x H
4.2	 5966109 5966110 5966111	Stroke applicator 4114L-200	xxxxxxx	Tamp pad 4114L-11 F W x H
		Stroke applicator 4114L-300	xxxxxxx	Tamp pad with damping layer 4114L-12 F W x H
4.2	 5971795 5972016 5972017	Stroke applicator 4116L-200	xxxxxxx	Tamp pad with label stop 4114L-61 F W x H
		Stroke applicator 4116L-400	xxxxxxx xxxxxxx	Blow pad 4114L-2100 W x H Form pad 4114L-8800 W x H
4.3	 5966117 5966118 5966119	Stroke turn applicator 4214L-200	xxxxxxx	Tamp pad 4214L-11 F W x H
		Stroke turn applicator 4214L-300	xxxxxxx	Tamp pad with damping layer 4214L-12 F W x H
4.3	 5966119	Stroke turn applicator 4214L-400	xxxxxxx	Tamp pad with label stop 4214L-61 F W x H
			xxxxxxx	Blow pad 4214L-2100 W x H
4.4	 5966133 5966134 5966135	Stroke applicator 4414L-200	xxxxxxx	Tamp pad 4414L-11 F W x H
		Stroke applicator 4414L-300	xxxxxxx	Tamp pad with damping layer 4414L-12 F W x H
4.4	 5966135	Stroke applicator 4414L-400	xxxxxxx	Tamp pad with label stop 4414L-61 F W x H
4.5	 5971625 5966168 5971640	Swing stroke applicator 4514L-200	xxxxxxx	Blow pad 4514L-2100 W x H
		Swing stroke applicator 4514L-300		
4.5	 5971640	Swing stroke applicator 4514L-400		
4.6	 5971815	Flag applicator 4712L-300 a separate leaflet is in preparation	xxxxxxx	Form padW x H a separate leaflet is in preparation
4.7	 5970100 5970101 5970102	Front side applicator 3014L-200	xxxxxxx	Tamp pad 3014L-1100 W x H
		Front side applicator 3014L-300	xxxxxxx	Tamp pad spring-mounted 3014L-3100 W x H
4.7	 5970102	Front side applicator 3014L-400	xxxxxxx	Blow pad 3014L-2100 W x H
		Front side applicator 3016L-200	xxxxxxx	Tamp pad 3016L-1100 W x H
4.7	 5970104 5970105	Front side applicator 3016L-300	xxxxxxx	Tamp pad spring-mounted 3016L-3100 W x H
		Front side applicator 3016L-400		
4.8	 5966101 5966102 5966103	Stroke applicator 4014L-200	5966147	Universal pad 4014L-1100 75 x 60
		Stroke applicator 4014L-300	5966148	Universal pad 4014L-1100 90 x 90
4.8	 5966103	Stroke applicator 4014L-400	5966149	Universal pad spring-mounted 4014L-3100 116 x 102
			5966150	Universal pad spring-mounted 4014L-3100 116 x 152
4.8	 5966161 5966162 5966163	Stroke applicator 4016L-200	xxxxxxx	Tamp pad 4014L-11 F W x H
		Stroke applicator 4016L-300	xxxxxxx	Blow pad 4014L-2100 W x H
4.8	 5966163	Stroke applicator 4016L-400	xxxxxxx	Tamp pad spring-mounted 4014L-3100 W x H
			xxxxxxx	Roll-on pad 4014L-4100 W x H
4.9	 5971720 5971725 5971730	Stroke blow applicator 4614L-200	xxxxxxx	Blow pad 4614L-2100 W x H
		Stroke blow applicator 4614L-300		
4.9	 5971730	Stroke blow applicator 4614L-400		
4.10	 5966144 5966146	Demand module 5114L		
		Demand module 5116L		
4.11	 5972730 5972750	Vacuum belt applicator 5314L-3		
		Vacuum belt applicator 5316L-3		
4.11	 5972940 5972920	Vacuum belt applicator 5414L-3		
		Vacuum belt applicator 5416L-3		
4.12	 5984810	Air jet box 5 templates are included	5984709.001	Template (5 are included in a pack unit) 6114 L/R

Delivery program of applicators R

Pos.	Part no.	Applicators R	Part no.	Transfer modules	
4.1	 5971655	Swing applicator 3214R-40	xxxxxxx xxxxxxx xxxxxxx xxxxxxx	Tamp pad Tamp pad with damping layer Tamp pad with label stop Blow pad 3214R-11 F W x H 3214R-12 F W x H 3214R-61 F W x H 3214R-2100 W x H	
4.2		5966113 5966114 5966115	Stroke applicator 4114R-200 Stroke applicator 4114R-300 Stroke applicator 4114R-400	xxxxxxx xxxxxxx xxxxxxx xxxxxxx xxxxxxx	Tamp pad Tamp pad with damping layer Tamp pad with label stop Blow pad Form pad 4114R-11 F W x H 4114R-12 F W x H 4114R-61 F W x H 4114R-2100 W x H 4114R-8800 W x H
		5972018 5972019 5972020	Stroke applicator 4116R-200 Stroke applicator 4116R-300 Stroke applicator 4116R-400	xxxxxxx xxxxxxx xxxxxxx xxxxxxx	Tamp pad Tamp pad with damping layer Tamp pad with label stop Form pad 4116R-11 F W x H 4116R-12 F W x H 4116R-61 F W x H 4116R-8800 W x H
4.3		5966121 5966122 5966123	Stroke turn applicator 4214R-200 Stroke turn applicator 4214R-300 Stroke turn applicator 4214R-400	xxxxxxx xxxxxxx xxxxxxx xxxxxxx	Tamp pad Tamp pad with damping layer Tamp pad with label stop Blow pad 4214R-11 F W x H 4214R-12 F W x H 4214R-61 F W x H 4214R-2100 W x H
4.4		5966137 5966138 5966139	Stroke applicator 4414R-200 Stroke applicator 4414R-300 Stroke applicator 4414R-400	xxxxxxx xxxxxxx xxxxxxx	Tamp pad Tamp pad with damping layer Tamp pad with label stop 4414R-11 F W x H 4414R-12 F W x H 4414R-61 F W x H
4.5		5966950 5971460 5971700	Swing stroke applicator 4514R-200 Swing stroke applicator 4514R-300 Swing stroke applicator 4514R-400	xxxxxxx	Blow pad 4514R-2100 W x H
4.7		5970106 5970107 5970108	Front side applicator 3014R-200 Front side applicator 3014R-300 Front side applicator 3014R-400	xxxxxxx xxxxxxx xxxxxxx	Tamp pad Tamp pad spring-mounted Blow pad 3014R-1100 W x H 3014R-3100 W x H 3014R-2100 W x H
		5970109 5970110 5970111	Front side applicator 3016R-200 Front side applicator 3016R-300 Front side applicator 3016R-400	xxxxxxx xxxxxxx	Tamp pad Tamp pad spring-mounted 3016R-1100 W x H 3016R-3100 W x H
4.8		5966105 5966106 5966107	Stroke applicator 4014R-200 Stroke applicator 4014R-300 Stroke applicator 4014R-400	5966140 5966141 5966142 5966143	Universal pad Universal pad Universal pad spring-mounted Universal pad spring-mounted 4014R-1100 75 x 60 4014R-1100 90 x 90 4014R-3100 116 x 102 4014R-3100 116 x 152
				xxxxxxx xxxxxxx xxxxxxx xxxxxxx xxxxxxx	Tamp pad Blow pad Tamp pad spring-mounted Roll-on pad Corner-wrap pad 4014R-11 F W x H 4014R-2100 W x H 4014R-3100 W x H 4014R-4100 W x H 4014R-5100 W x H / H
		5966165 5966166 5966167	Stroke applicator 4016R-200 Stroke applicator 4016R-300 Stroke applicator 4016R-400	xxxxxxx xxxxxxx xxxxxxx	Tamp pad Tamp pad spring-mounted Roll-on pad 4016R-11 F W x H 4016R-3100 W x H 4016R-4100 W x H
4.9		5971735 5971740 5971745	Stroke blow applicator 4614R-200 Stroke blow applicator 4614R-300 Stroke blow applicator 4614R-400	xxxxxxx	Blow pad 4614R-2100 W x H
4.10		5966145 5966152	Demand module 5114R Demand module 5116R		
4.11		5972740 5972760	Vacuum belt applicator 5314R-3 Vacuum belt applicator 5316R-3		
		5972950 5972930	Vacuum belt applicator 5414R-3 Vacuum belt applicator 5416R-3		
4.12		5984800	Air jet box 5 templates are included 6114R	5984709.001	Template (5 are included in a pack unit) 6114 L/R

xxxxxxx - user specific part no. following request

Delivery program of HERMES Q accessories

Pos.	Part no.	Accessories
2.1	5977370	SD memory card 8 GB
2.2	5977730	USB memory stick 8 GB
2.3	5978912.001	USB WLAN stick 2.4 GHz 802.11b/g/n
2.4	5977731	USB WLAN stick with a rod antenna 2.4 GHz 802.11b/g/n + 5 GHz a/n/ac
2.5	5977732	USB Bluetooth adapter
2.6	5970071	Product sensor, 3 pin
2.7	5964300	Product sensor, 25 pin
2.8	6010520	2-Port Ethernet Switch 10/100 Mbit/s
2.9	5917651	I/O interface connector SUB-D, 25 pin
2.10	6010560	Warning light
2.11	5954978.001 5954985.001 5954979.001	Print roller DRS2 Print roller DRS4 Print roller DRS6
2.12	5961751.001 5961752.001	Draw roller ZU4 Draw roller ZU6
2.13	6010586	Spacers L retrofit kit for small materials
	6010590	Spacers R retrofit kit for small materials
2.14	5961640.001 5961642.001 5961644.001 5961646.001	Antistatic brush 2L Antistatic brush 2R Antistatic brush 4L Antistatic brush 4R
2.15	5961650	Margin stop
2.16	6010186 5907718 5907730 5907750 5907760 5907765	External operation panel Connecting cable USB, 1.8 m Connecting cable USB, 3 m Connecting cable USB, 5 m Connecting cable USB, 11 m Connecting cable USB, 16 m
2.17	5948205	Label selection - I/O box
2.18	5955710	Hand switch TR2
2.19	5955711	Foot switch
2.20	5550818	Connecting cable RS232 C 9/9 pin, length 3 m
2.21	on request	Barcode tester CC200

Pos.	Part no.	Options (assembly ex factory)
3.1	6010500 6010501 6010502	Cover 2L Cover 4L Cover 6L
	6010503 6010504 6010505	Cover 2R Cover 4R Cover 6R
3.2	6010557 6010558 6010559 6010563 6010564 6010565	Extended peel-off plate HERMES Q2L Extended peel-off plate HERMES Q4L/Q4.3L Extended peel-off plate HERMES Q6.3L Extended peel-off plate HERMES Q2R Extended peel-off plate HERMES Q4R/Q4.3R Extended peel-off plate HERMES Q6.3R
Pos.	Part no.	Assembly aids
6.1	5965940	Adapter plate
6.2	on request	Profile (customer-specific length)
6.3	5961203	Base plate 500 x 255 mm
6.4	5958400	Mounting plate
6.5	5955685	Bracket
6.6	8914443	Clamped joint for profile 50 x 50 mm
6.7	8914444	Flanged joint for profile 50 x 50 mm
6.8	5970113	Floor stand 1601
6.9	5970112	Floor stand 1602
Pos.	Part no.	Accessories applicators
5.13	5964277.001 5964095.001 5964614.001	Blow tube 2" Blow tube 4" Blow tube 6"
5.14	5955735 5955736	Compressed air regulation unit L Compressed air regulation unit R
5.16	5984805 5984795	Compressed air regulation unit L with shut-off valve for air jet box 6114L Compressed air regulation unit R with shut-off valve for air jet box 6114R
5.17	596xxx.212	Pressure reducing valve
Pos.	Part no.	Label software
7.6	Bundle 5588001 5588100 5588101 5588150 5588151 5588152 5588002 5588105 5588106 5588155 5588156 5588157	cablabel S3 Lite (Download at cab.de/en) cablabel S3 Pro, 1 WS cablabel S3 Pro, 5 WS cablabel S3 Pro, 10 WS cablabel S3 Pro, 1 additional licence cablabel S3 Pro, 4 additional licences cablabel S3 Pro, 9 additional licences cablabel S3 Print, 1 WS cablabel S3 Print, 5 WS cablabel S3 Print, 10 WS cablabel S3 Print, 1 additional licence cablabel S3 Print, 4 additional licences cablabel S3 Print, 9 additional licences
	in preparation	cablabel S3 Print Server
7.10	9008486	Programming manual EN, printed copy

cab product overview

Label printers
MACH1, MACH2



Label printers
EOS 2



Label printers
EOS 5



Label printers
MACH 4S



Label printers
SQUIX 2



Label printers
SQUIX 4



Label printers
SQUIX 6.3



Label printer
A8+



Label printer
XD4T



Label printers
XC



Print and apply systems
HERMES Q



Print and apply systems
Hermes C

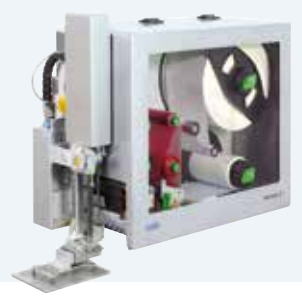

Tube labeling systems
AXON



Print modules
PX Q



Labels and ribbons



Label software
cablabel S3



Label dispensers
HS, VS



Labeling heads
IXOR



Marking lasers
XENO 4



Laser marking systems



Germany
cab Produkttechnik GmbH & Co KG
Karlsruhe
Phone +49 721 6626 0
www.cab.de

France
cab Technologies S.à.r.l.
Niedermodern
Phone +33 388 722501
www.cab.de/fr

USA
cab Technology, Inc.
Chelmsford, MA
Phone +1 978 250 8321
www.cab.de/us

Mexico
cab Technology, Inc.
Juárez
Phone +52 656 682 4301
www.cab.de/es

Taiwan
cab Technology Co., Ltd.
Taipei
Phone +886 (02) 8227 3966
www.cab.de/tw

China
cab (Shanghai) Trading Co., Ltd.
Shanghai
Phone +86 (021) 6236 3161
www.cab.de/cn

China
cab (Shanghai) Trading Co., Ltd.
Guangzhou
Phone +86 (020) 2831 7358
www.cab.de/cn

South Africa
cab Technology (Pty) Ltd.
Randburg
Phone +27 11 886 3580
www.cab.de/za

cab // 820 distribution partners in more than **80** countries

cab
we identify more